

### High Current AC/DC Feedthrough Filter 400 Amp — High Reliability



- ✓ Excellent EMI filtering
- ✓ Compact and lightweight
- ✓ "C" Type Filter
- ✓ High Shock & Vibration
- ✓ High Reliability per MIL-PRF-49467
- ✓ MIL-PRF-55681, MIL-PRF-123, SCD available
- ✓ CDR and JAN Reliability levels available

### Voltage & Capacitance

400A			Capacitance $\mu\text{F}$																						
			.01	.015	.022	.033	.047	.068	.1	.15	.22	.33	.47	.68	1.0	1.5	2.2	3.3	4.7	6.8	10	15	22		
Rated Voltage	Vdc	50	+																						
		100	+																						
		200	+																						
		500	+																						
	Vac	120	+																						
250		+																							

+ Standard Values

### Insertion Loss

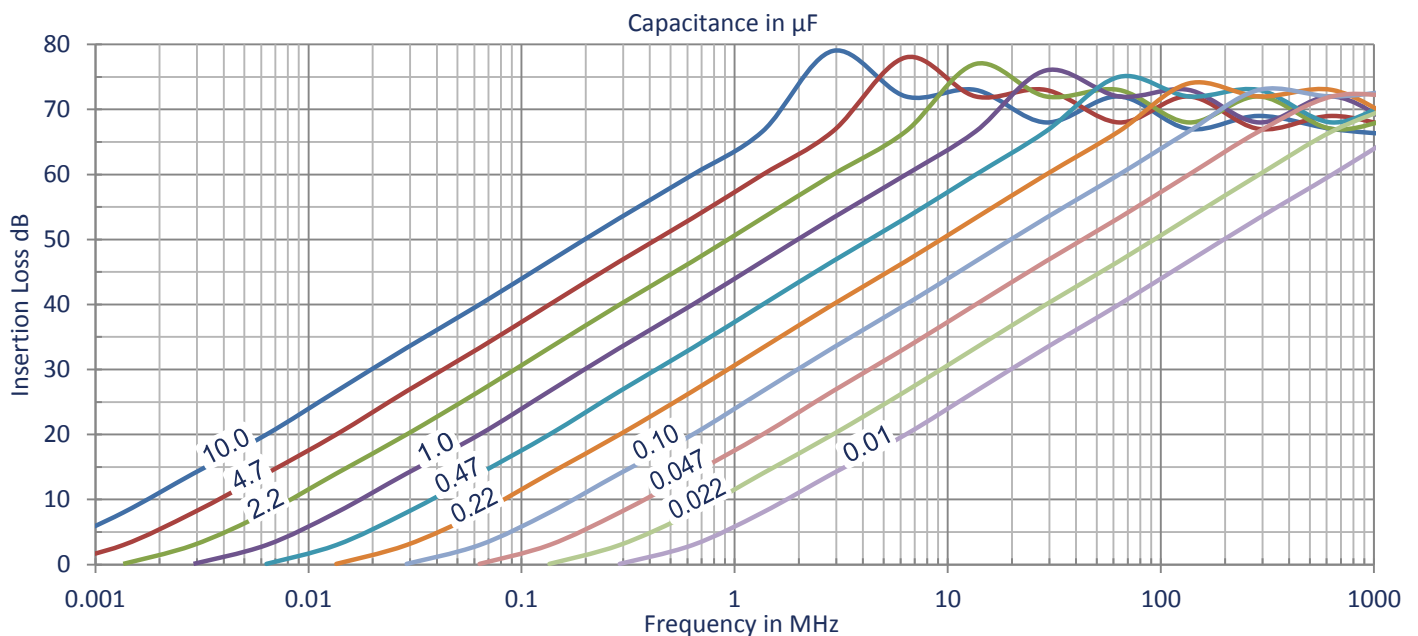

## High Reliability

**MIL-C-49467 Group A (Custom units to MIL-C-55681, MIL-C-123 or customer SCD available)**

Parameter	Value	Specification
Burn In	125°C / Rated Voltage / 96 hours	MIL-STD-202 Method 108A Cond A
Thermal Shock	-55°C to +125°C / 5 cycles	MIL-STD-202 Method 107D / Cond B Modified
Altitude	70,000' (21.3km or 33mm Hg)	
Vibration (high freq)	0.06"DA / 20g <sub>pk</sub> 10Hz-3kHz	MIL-STD-202 Method 204D / Cond F
Vibration (Random)	11.6g <sub>rms</sub> 50Hz – 2kHz, 90min	MIL-STD-202 Method 214 / Cond D

## Specifications

Parameter	Value	Description / Specification/ Method
Current	400 Amperes	50, 55, 140, 175, 250, & 400 Amps available
Insertion Loss	See Performance Curve on page 1	Per Capacitor Value
RF Current	15A <sub>rms</sub>	
Insulation Resistance	100ΩF (100MΩ Maximum) at 25°C	MIL-STD-202 Method 302
Dielectric Withstand Voltage	250% Rated Voltage (50mA 5s)	MIL-STD-202 Method 301
Dissipation Factor	3% Maximum	MIL-STD-202 Method 306
Voltage Drop	19mV	Wire to Wire
Operating Temp	-55°C to +125°C	40A@125°C to 400A@105°C
Temperature Rise	22.4°C Typical at 400A	
Heat Rise Constant	2.3 to 4.0	C <sub>1</sub> in formula $\Delta T = C_1 \times W^{0.85}$
Storage Temperature	-55°C to +105°C	
Fungus	Non-Nutrient	MIL-HDBK-454A
Corrosion (metal finish)	5% NaCl / 35°C / 48 hrs	MIL-STD-202 Method 101D / Cond B
Humidity	98%RH 25°C-65°C	MIL-STD-202 Method 106E
Shock	50g – 11ms	MIL-STD-202 Method 213B / Cond A
Terminal Strength	Torque: 200 in-lbs (22N·m) Pull: 200lbs (91kg)	MIL-STD-202 Method 211A / Cond A & E
Reliability(MTBF)	500,000 hrs	MIL-HDBK-217F Cond - N2 A(IF) 70°C 50%V

## Mechanical Specifications

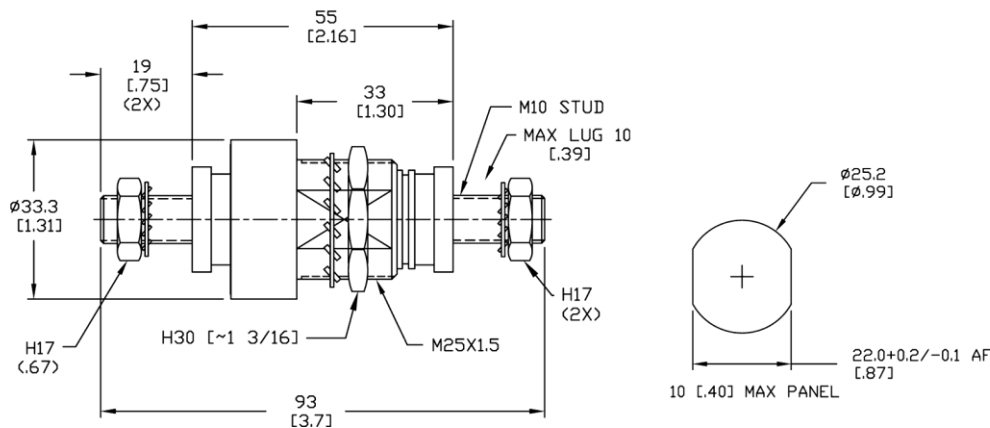

Component	Material	Finish
Metal Parts	Copper Alloy	Nickel
Insulator	FR4 or Nylon	-

### Mounting

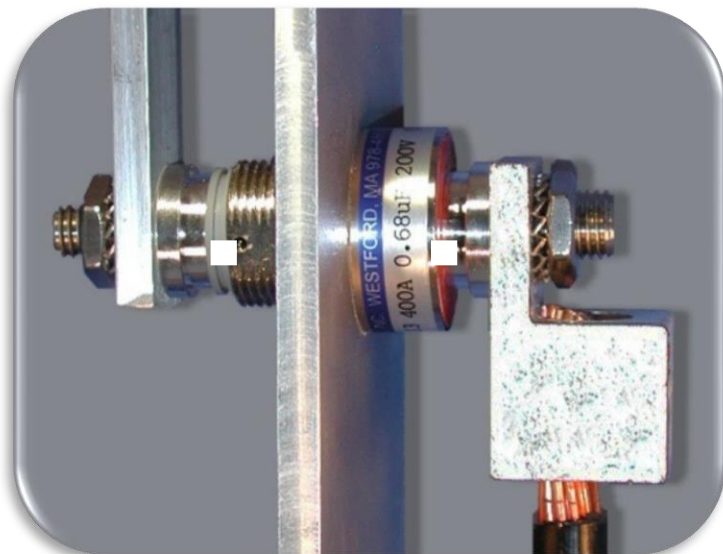

#### INSTALLATION NOTE:

Always place current-carrying wire lug or busbar directly against the flat electrode face of the HPR400. Do not use any hardware (lockwashers, extra nuts, etc.) between the current-carrying conductor and this flat electrode face.

#### Installation Torque Recommendations

Electrode Lug Nut (e) Torque: 200 in-lbs (22 N·m)  
Mounting Panel Nut (c) Torque: 300 in-lbs (34 N·m)

### Part Number

Device	Current	Capacitance	Tolerance	Voltage	Series
HPR	400	XXXX	X	XX	X

<b>Device</b>	HPR High Current Feedthrough Filter
<b>Current</b>	Current rating in amperes
<b>Capacitance</b>	in picofarads, first two digits are significant, last two digits are number of zeros e.g. 2203 = 22,000pF / 4704 = .47μF
<b>Tolerance</b>	Capacitor Code: Z= +80%/-20% (Standard), M= +/-20%, K= +/-10%, J=+/-5%
<b>Voltage</b>	Rating Code: 05=50V, 10=100V, 20=200V, 50=500V, 1K=1000V, 1A=120Vac, 2A=240Vac
<b>Series</b>	Optional series designator

**Example:** HPR4001004Z10E = Feedthrough Filter / 400A / 0.10uF / +80%/-20% / 100Vdc / E-Series

### Safety Tips

- ✓ The filter should be mounted in a grounded shielding panel
- ✓ Tighten the electrode nuts to the torque specified.
- ✓ Cover exposed electrode nuts
- ✓ Observe temperature, current, & voltage limit
- ✓ Always install lug or busbar directly against center boss

*This specification is for reference only and is subject to change without notice*