

HEMP & NEMP Fine Protector - Surge Arrestor
Special Electrical POE Protective Device per MIL-STD-188-125-1

Protection for
HF-GCS
Telemetry
ISB - ALE



Features:

- ✦ Sub-Nanosecond Response Time
- ✦ Frequency range: 1 – 50MHz
- ✦ N Type Connectors - Protected Female Side
- ✦ 30A LEMP or 60A NEMP Protection
- ✦ Designed for MIL-STD 188-125-1, MIL-STD-461, & MIL-STD-464
- ✦ Excellent RF Performance

RF Specifications

Frequency (MHz)	VSWR	Insertion Loss (dB)
1 - 50	1.10 typ	.10 typ

- ✦ Nominal Impedance – 50Ω
- ✦ Through Current: No dc Pass
- ✦ RF Power: 100mW
- ✦ Voltage: Nominal ±3.0 Vpk

Transient Specifications

- ✦ Response Time: < 1ns
- ✦ Transient
30A 10x (8X20μs waveform)
60A 10x (20x500ns waveform)

Let-Through Energy (10A input)	
LEMP (8X20μs)	±1.2V
NEMP (20x500ns)	±2.5V

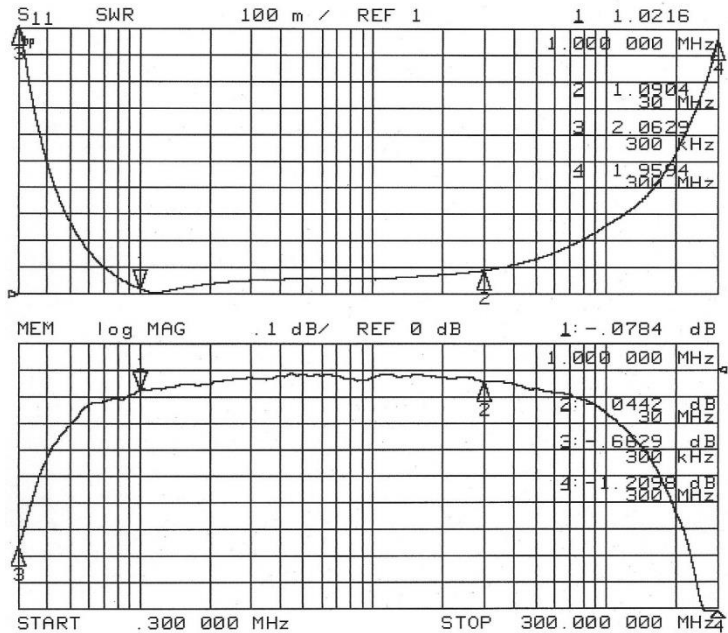

Typical VSWR and Insertion Loss

Mechanical Specifications

Weight: 4.8 ounces [135 grams]

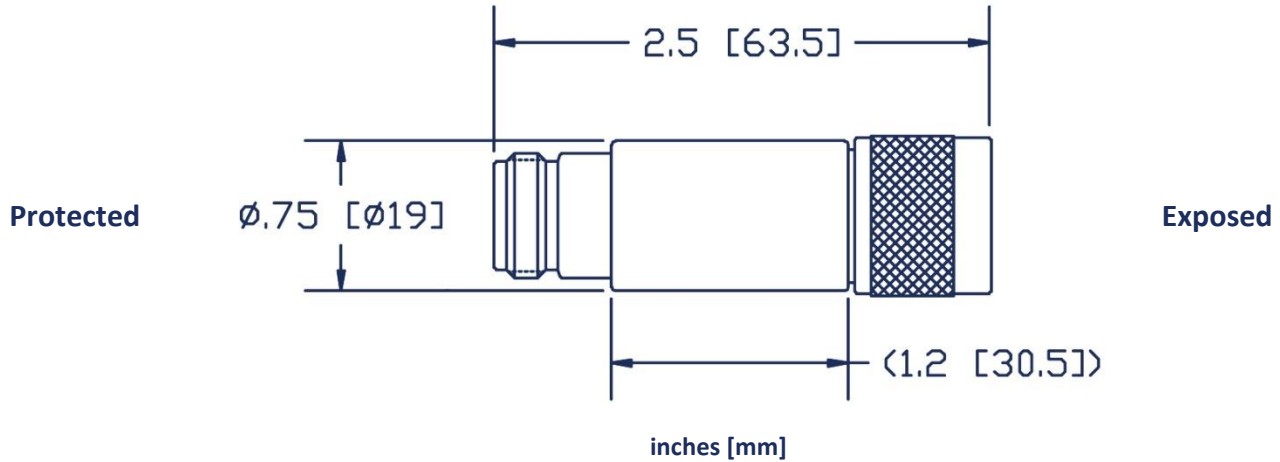

Material and Finish

Component	Material	Finish
Outer Parts	Brass	Nickel
Center Contact	BeCu	Gold
Insulator	PTFE	-
Gasket	EPDM or SIL	-

This product is an example of NexTek's ultra-high-speed NEMP/HEMP suppressor technology. This family of devices is available with a variety of clamping voltages, connector configurations, and protected/unprotected orientations. Please contact NexTek, Inc. with your requirements for help with choosing the proper protection.

Environmental Specifications

Temperature Range	-40°C to +90°C
Salt Fog	MIL-STD-202 Method 101D / Condition B (35°C/48 hrs)
Immersion	MIL-STD-202 Method 104A / Condition A (65°C to 25°C w/NaCl – 2 cycles)
Moisture Resistance	MIL-STD-202 Method 106E (65°C/98% RH condensing/240 hrs)
Temperature Shock	MIL-STD-202 Method 107D / Condition B-1 (25 cycles -65°C to +125°C)
Life (Elevated Temperature)	MIL-STD-202 Method 108A / Condition A (96 hours at 100°C)
Dust and Waterproof Rating	IEC529 IP68 (dust-tight and water proof 24 hrs / 1 m)
Vibration	MIL-STD-202 Method 204D / Condition D (10Hz-2kHz 0.06"DA/20g)
Mechanical Shock	MIL-STD-202 Method 213 / Condition A (50g/11ms ~24")