

## Selecting Coaxial Lightning Protectors

By George M. Kauffman, PE

Coaxial cables are often used for high frequency signal transmission in situations that significantly increase the risk of lightning energy and damage. This article will touch on the most important parameters for the selection of a coaxial lightning protector; including, Radio Frequency (RF) performance, connector type protection capability and configuration.

### RF Performance

Coaxial protectors are intended to pass through a desired RF signal with minimum loss or disturbance. When RF energy enters a protector, the energy is, in some combination, passed through, reflected back, and dissipated within the device. The fundamental RF performance parameters of a coaxial connector are RF frequency and the corresponding insertion loss and VSWR (or return loss). The loss of signal level through the protector is called Insertion Loss and is measured in decibels (dB). The reflection of a signal back to the source is measured as VSWR (or return loss) also in dB.

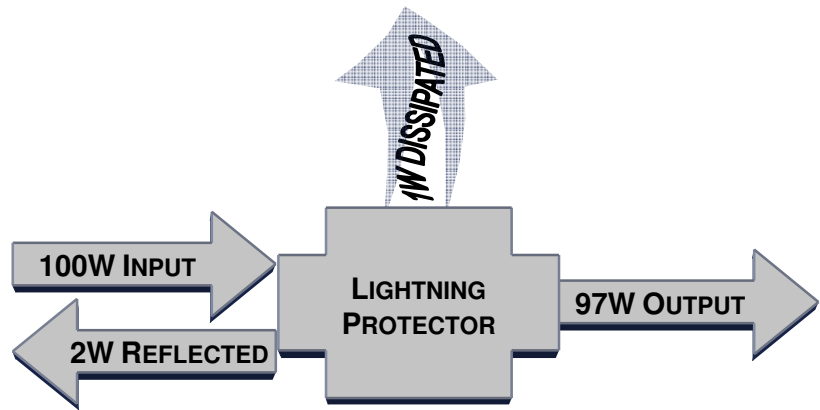

In this example the insertion loss is  $10 \times \log(97/100)$  or 0.13 dB. The return loss is  $10 \times \log(2/100)$  or 17dB. This return loss is equivalent to a VSWR of 1.33.

**Rule: To minimize the impact of inserting lightning protectors within the RF circuit, seek out products with the lowest Insertion Loss and lowest VSWR at the frequencies that you intend to operate.**

Return Loss (dB)	VSWR
6.0	3.01
7.4	2.50
7.9	2.36
9.0	2.10
11.0	1.78
12.6	1.61
14.5	1.47
16.6	1.35
17.7	1.30
19.0	1.25
20.3	1.21
23.2	1.15
24.8	1.12
26.6	1.10
30.4	1.06

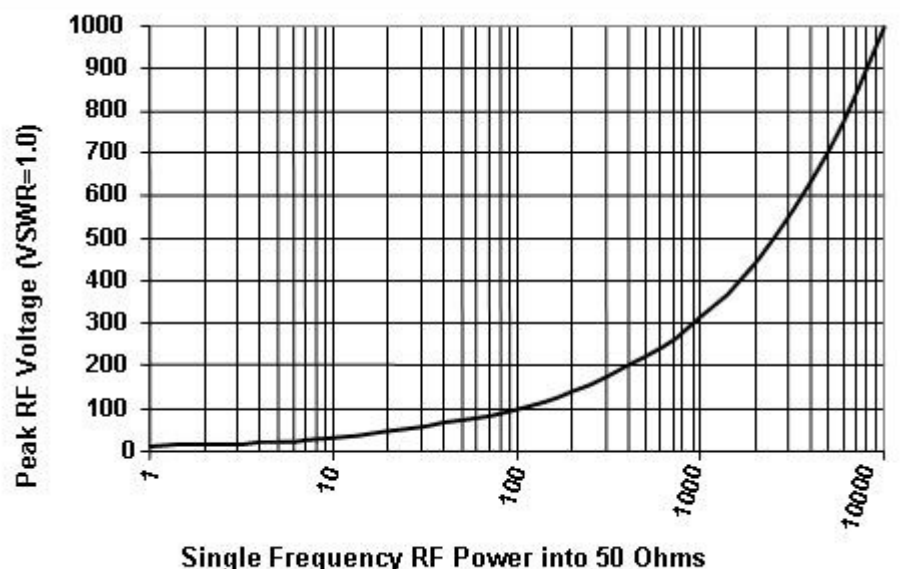

The RF power of a circuit produces a voltage on the center conductor. In most cases the system impedance is 50Ω, so the relationship between power and voltage can be expressed as the familiar  $W = V^2/50 \Omega$ . The actual voltage is increased by the VSWR value of the entire system, including the antenna and the end termination.

In cases of multiple simultaneous transmission bands it is necessary to calculate the voltage for each RF frequency separately and sum.

RF Power		RF Voltage (50 Ω VSWR=1.0)	
W	dBm	V <sub>rms</sub>	V <sub>peak</sub>
0.0001	-10.00	0.071	0.10
0.001	0.00	0.224	0.32
0.01	10.0	0.71	1.00
0.1	20.0	2.24	3.16
1	30.0	7.07	10.0
2	33.0	10.0	14.1
5	37.0	15.8	22.4
10	40.0	22.4	31.6
20	43.0	31.6	44.7
50	47.0	50.0	70.7
100	50.0	70.7	100
200	53.0	100.0	141
500	57.0	158.1	224
1000	60.0	223.6	316

Some applications require multiple simultaneous transmission and receiving. For most telecom applications, specifying the Inter-Modular Interference (IMI) or Passive Inter-Mod (PIM) interference is typically required. PIM is usually specified in dB, similar to return loss. More traditional electrical parameters (volts and amperes) are required if dc power is required, particularly if the coaxial cable carries power for far end equipment in addition to the RF signals.

### Connector Types

The connector types most commonly used for communication systems include the N, 7-16 DIN, TNC and the SMA connector. In addition, the 75 Ohm F connector is popular in video/cable applications. Each connector brings a specific geometry of both the inner conductor and outer conductor; in most connectors the outer conductor has a significantly greater current capacity than the center pin. This is beneficial because the outer shield is usually connected to

the grounding system and can take a substantial portion of the lightning current. In addition, the transient current capacity limitation of the center pin should also be considered. The current rating of most center pins is rated as the survivability of ten 8x20μs ampere pulses, shown in Table X below.

Transient Capacity in kA		Connector type							
		Connector	7-16 DIN	UHF	N	TNC	BNC	SMA	F(75Ω)
Quality	Pin Diameter		0.276"/7mm	0.19"/4.8mm	0.12"/3.1	0.08"/2.1mm		0.05"/1.3mm	~.04"/1mm
	Higher		100kA	50kA	30kA	20kA	20kA	5kA	15kA
	Lower		50kA	10kA	10kA	5kA	5kA	2.5kA	3kA

Table X.

Larger connector pin formats have a longer lifetime rating. The largest differentiator between high and low quality protectors is the female contact material and finish. The female contacts for smaller format connectors, particularly of N, TNC or BNC and SMA configurations, must be a hardened copper alloy for maximum pulse lifetime. Low quality protectors use soft bronze or even softer brass female sockets, which can easily be bent or loosened during assembly or mating, and are further weakened with the heating caused by high lightning currents. You can confirm your pin material this with a simple test: Find a paper clip, or pin, that will just fit into the connector socket. Insert the pin into the female socket and angle the pin about 20°-30° from the pin centerline to bend open a socket spring finger. Return the pin to the center and withdraw the pin from the socket. If spring finger of the pin returns to its original position, you have a high quality contact. Under severe bending, a high quality pin will break off, as opposed to staying bent. If the spring finger stays bent, do not use this female connector type (whether on the protector or on the attached cable). NexTek uses specialized contacts for long pulse lifetime including hardened copper alloy pins

with gold finish for female contact in all N and TNC/BNC and SMA protectors. Other techniques are used to extend the life of 7-16 and UHF female contacts.

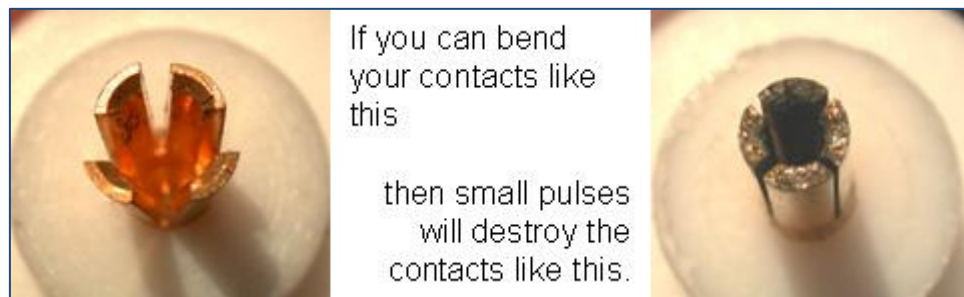

Each connector type has inherent maximum voltage, current, and RF power limitations. Be sure to select a connector that is compatible with the radio manufacturers' recommendations, particularly for higher RF power applications.

## Protection Capability and Performance

The protection capability and performance includes the maximum transient capability of the protectors and the ability to reduce high voltages to safer and acceptable levels. The protection capability of a protector is usually rated in its ability to guard against or survive  $8 \times 20 \mu\text{s}$  lightning current pulses.

### *Gas Discharge Tube (GDT) Protectors*

If the signal is less than 400 MHz, or the protector must pass dc, most protectors rely on a Gas Discharge Tube (GDT) which triggers when a large voltage appears and shorts out the remaining transient. GDTs are a reliable, long life workhorse of the industry and have the highest transient current capability for their size of any similar protection component. The transmission peak RF voltage should be less than 60% of the GDT voltage rating, otherwise the GDT may react to the normal RF voltage levels. Also, since the GDT voltage is rated higher than the normal RF voltage and the GDT takes some time to respond, a very short pulse associated with these two factors will occur on the protected line.

The current capacity of industry standard GDT's range from a lifetime of ten 20kA pulses to lower values of 5kA pulses. While GDTs usually have a very long lifetime, UHF and especially 7-16 type connectors will easily outlast even the highest quality GDT. Therefore, protectors using these connector types should allow for a replaceable GDT and periodic replacement. Protectors using SMA, F, or BNC connectors typically do not benefit from a replaceable GDT; because when the GDT requires replacement, most likely the center pin has also been damaged.

If the more rugged N and sometimes the TNC connectors are protected from direct strikes, a high quality GDT has a very long life expectancy. However, in high risk areas the GDT might degrade. The GDT lifetime can be managed in three ways:

- a. replacing the entire protector periodically or upon equipment damage,
- b. use of redundant protectors on the line, so that when the first protector and connector or wire is damaged, the second protector will continue to protect, or
- c. replacing the GDT component.

If you periodically replace a GDT or the whole protector, remember the cable or connector is not being renewed, and requires inspection if poor transmission is observed.

The best way to reduce long term expenses and ensure high availability service for TNC and especially N or 7-16 connectors is to require a minimum 20kA (10  $8 \times 20 \mu\text{s}$  pulses) lifetime, or 50kA one pulse rated protectors. There is no reason to accept a shorter life protector such as 5kA or 10kA, unless very high frequency operation or a smaller format connector is required.

### *Shorted Conductor Protectors*

If the signal is over 400 MHz to over 6GHz and there is no dc present in the application, the protector of choice is either a quarter wave stub or inductor shorting design. Called pass band devices, these protectors use a high current capacity shunt from the center conductor to the outer conductor. These protectors exhibit remarkable RF performance, especially above 3 GHz.

Since there is no voltage sensitive component used in the protection scheme, the RF power capability of a quarter-wave stub protector is usually coordinated with the RF connector. In addition, the shunt current capacity can be matched to the connector pin type, so that longer lifetime protectors are the norm for larger connector size quarter wave protectors. DIN 7-16 protectors can have ratings of 100kA or more. N protectors can have ratings of 60kA.

Finally, since there is no turn-on delay similar to a GDT, there is a much more limited voltage overshoot upon operation. Quarter wave stub protectors have a long lifetime and provide exceptional transient current capacity with excellent protection.

### *Let-Through*

The ability to protect is usually evaluated by injecting a standard impulse and measuring what passes through the protector. The most common input is a 1.2x50µs voltage waveform with an 8x20ns current waveform. The 1.2x50 is defined, as in the current waveform, as rise time of 1.2µs and pulse width of 50ns. The most common term is “let-through” and is usually stated in peak voltage and energy. With an input of 6kV/3kA the let-through for GDT based protectors is about 600Vpeak and 300µJ. The GDT typically triggers in 100ns. A quarter wave stub based protector has a typical let-through of 15V and 10µJ.

Some protectors use additional components, such as dc blocks, which can reduce let-through, but at the sacrifice of bi-directional protection. Bi-directional means that the transient can enter the protector from either side. In real applications, transients can occur from the ac power mains, the coaxial cable or other metal members or conductors. It is usually important that a protector can protect a transient entry from either side. In addition, unidirectional protectors can inadvertently be installed “backwards”, resulting in virtually no protection. Also, the input stage of most transceivers have band pass filtering which can provide this same energy limiting action that works very well in the majority of applications

Most coaxial protectors use GDT or quarter wave (sometimes called inductor) technology as the fundamental protection element. Further refinements are available, including designs to overcome GDT lifetime or response delay, and other enhancements to significantly reduce let-through energy in both GDT and quarter wave stub protectors. For example, NexTek NEMP Fine Protectors can dramatically reduce let-through energy and response time.

## Configuration, Mounting and Grounding

The configuration of the protector can be used to make it easier to mount, connect and ground successfully. The figure below provides some general guidance on how to mount and ground a variety of protector styles. If the application is outdoors, waterproof units are required. Remember that grounding a protector is essential to ensure protection of susceptible equipment.

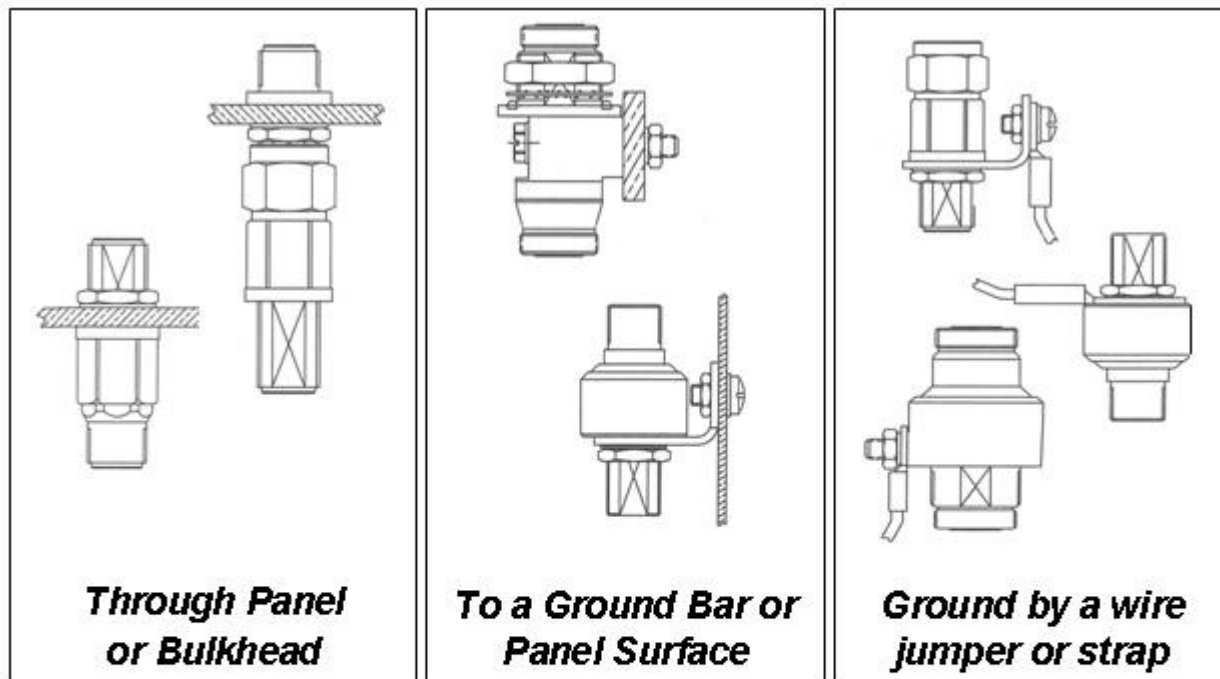

- Best grounding and shielding
- Strain relief loop needed for rigid cable
- Mount hole needed connector types
- Can piggyback on bulkhead feedthroughs

- Better grounding
- Easily installed with simple holes
- Cable should include drip/strain relief loop
- Bracket or M8 bolt
- High density cable runs possible

- Good grounding with flat straps or short wire
- Very easy installation
- Lug and bracket or M8 thread used
- Cable can flex and run in any direction
- Use large ground wire

## Conclusion

When selecting your coaxial protector use the following criteria.

1. Lowest insertion loss and VSWR for the frequency
2. Largest recommended connector type
3. Maximum Transient Capacity
4. Best Bi-directional Protection Level
5. Most convenient mounting and grounding