

## High Current DC Feedthrough Filter 250 Amp



- ✓ Excellent EMI filtering
- ✓ Compact and lightweight
- ✓ "C" Type Filter
- ✓ Bolt-in style
- ✓ High Shock & Vibration
- ✓ CDR and JAN Reliability levels available

### Voltage & Capacitance

250A		Capacitance $\mu\text{F}$																					
		.01	.015	.022	.033	.047	.068	.1	.15	.22	.33	.47	.68	1.0	1.5	2.2	3.3	4.7	6.8	10	15	22	
Rated Voltage	Vdc	50						+				+				+				+			
		100						+				+				+				+			
		200						+				+				+			+				
		500						+						+									

+ Standard Values

### Insertion Loss

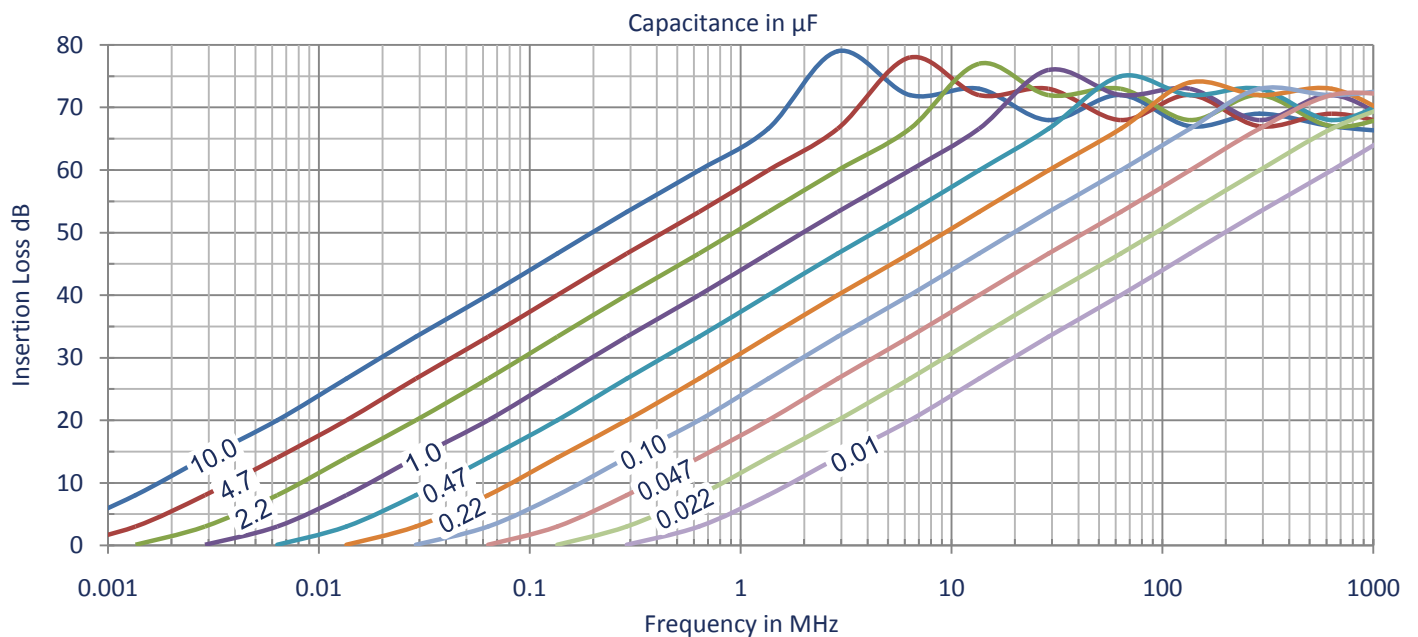

### Specifications (Units to MIL-C-49467, MIL-C-55681, MIL-C-123 or customer SCD available in E-Series)

Parameter	Value	Description / Specification / Method
Current	250 Amperes	50, 55, 140, 175, 250, & 400 Amps available
Insertion Loss	See Performance Curve on page 1	Per Capacitor Value
RF Current	12A <sub>rms</sub>	
Insulation Resistance	100ΩF (100MΩ Maximum) at 25°C	MIL-STD-202 Method 302
Dielectric Withstand Voltage	250% Rated Voltage (50mA 5s)	MIL-STD-202 Method 301
Dissipation Factor	3% Maximum	MIL-STD-202 Method 306
Voltage Drop	13mV	Wire to Wire
Operating Temp	-55°C to +125°C	25A@125°C to 250A@70°C
Temperature Rise	18.8°C Typical at 250A	
Heat Rise Constant	3.9 to 7.0	C <sub>1</sub> in formula $\Delta T = C_1 \times W^{0.85}$
Storage Temperature	-55°C to +105°C	
Fungus	Non-Nutrient	MIL-HDBK-454A
Corrosion (metal finish)	5% NaCl / 35°C / 48 hrs	MIL-STD-202 Method 101D / Cond B
Humidity	98%RH 25°C-65°C	MIL-STD-202 Method 106E
Shock	30g – 11ms	MIL-STD-202 Method 213B / Cond A
Terminal Strength	Torque: 250 in-lbs (28 N-m) Pull: 150lbs (68kg)	MIL-STD-202 Method 211A / Cond A & E
Reliability(MTBF)	500,000 hrs	MIL-HDBK-217F Cond - N2 A(IF) 70°C 50%V

### Mechanical Specifications

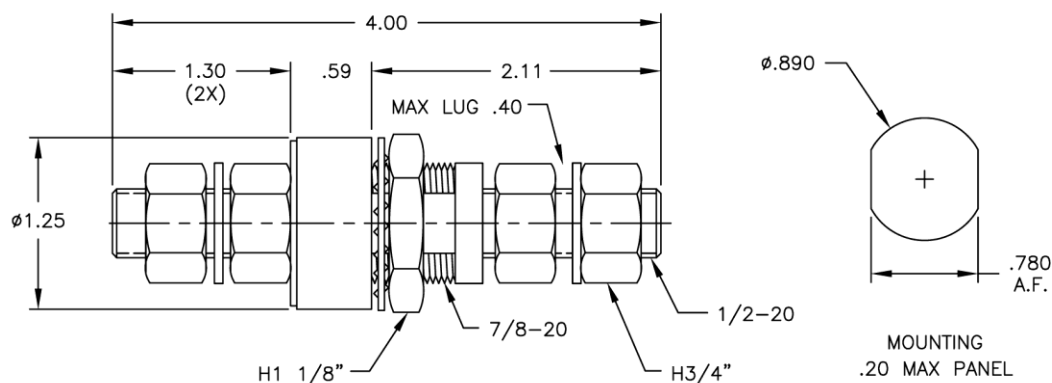

Component	Material	Finish
Metal Parts	Copper Alloy	Nickel
Insulator	FR4 or Nylon	-

*This specification is for reference only and is subject to change without notice*

### Mounting

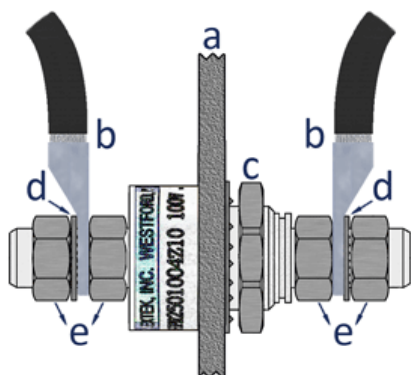

- a. Mounting Panel
- b. Lug / Wire
- c. Mounting Nut
- d. Lock Washer
- e. Electrode Lug Nut

### Installation Torque Recommendations

**NOTE:** Electrode Nuts (e) must be tightened using the Two-Wrench Method...Place an open end wrench on the electrode nut closest to the mounting panel (a) and a calibrated torque wrench on the outer electrode nut on the same side...Tighten nuts against one another.

The "two wrench method" will prevent any torque from developing between the electrode and the HPR body.

Electrode Lug Nut (e) Torque: 250 in-lbs (28 N·m)

Mounting Panel Nut (c) Torque: 300 in-lbs (34 N·m)

### Part Number

Device	Current	Capacitance	Tolerance	Voltage	Series
HPR	250	XXXX	X	XX	X

**Device** HPR High Current Feedthrough Filter

**Current** Current rating in amperes

**Capacitance** in picofarads, first two digits are significant, last two digits are number of zeros  
e.g. 2203 = 22,000pF / 4704 = .47μF

**Tolerance** Capacitor Code: Z= +80%/-20% (Standard), M= +/-20%, K= +/-10%

**Voltage** Rating Code: 05=50V, 10=100V, 20=200V, 50=500V

**Series** Optional series designator

**Example:** HPR2501004Z10 = Feedthrough Filter / 250A / 0.10uF / +80%/-20% / 100Vdc

### Safety Tips

- ✓ The filter should be mounted in a grounded shielding panel
- ✓ Tighten the electrode nuts to the torque specified with the two wrench method
- ✓ Cover exposed electrode nuts
- ✓ Observe temperature, current, & voltage limits

