

PGT RF Power Capability

This article describes how the PGT device allows high power while using a low protection voltage.

The RF power rating of NexTek PGT protectors is exceptionally high for two reasons. The first is due to the larger format 7-16 connector, which is capable of handling high RF through current levels. The internal clearances of the connector and protector tend to increase breakdown and corona voltage level to several thousands of volts. The circumference of the center conductor conducts substantially all of the RF current above 1 GHz, due to skin effect. NexTek's control of plating material and thickness, and optimized geometry, results in minimal loss and resultant heating.

The second, and even more important, reason that the NexTek PGT has high RF power rating is the configuration of the internal circuit. Referring to the simplified diagram a tap conductor is connected to the center coaxial conductor of the protector. This tap conductor has a length that corresponds to the quarter wavelength of the center frequency of the pass band. The other end of the tap conductor has an insulator preventing contact to the outer conductor, but has RF coupling to the outer conductor, due to the dielectric properties of the insulator. This RF coupling has low impedance. The in-band wave reflections of this stub causes the low impedance at the dielectric insulator end of the stub to be reflected as a high stub impedance at the center conductor end of the stub, allowing in-band signal to proceed through the protector without being "shorted out".

The Gas Discharge Tube (GDT) is located at the RF coupled end of the stub, and the low RF impedance to ground greatly reduces any RF voltage imposed on the GDT. The only voltage normally considered on the GDT is any dc voltage on the center conductor. With any reasonable dc voltage in the application, the voltage across the GDT is nearly independent applied RF power, to the point where selection of the GDT based on RF power is unnecessary.

The GDT used in the NexTek PGT has a nominal rating of 90 volts, and will allow dc circuits passing up to 48Vdc with a wide tolerance for battery float and charging voltages, to be on the center conductor.

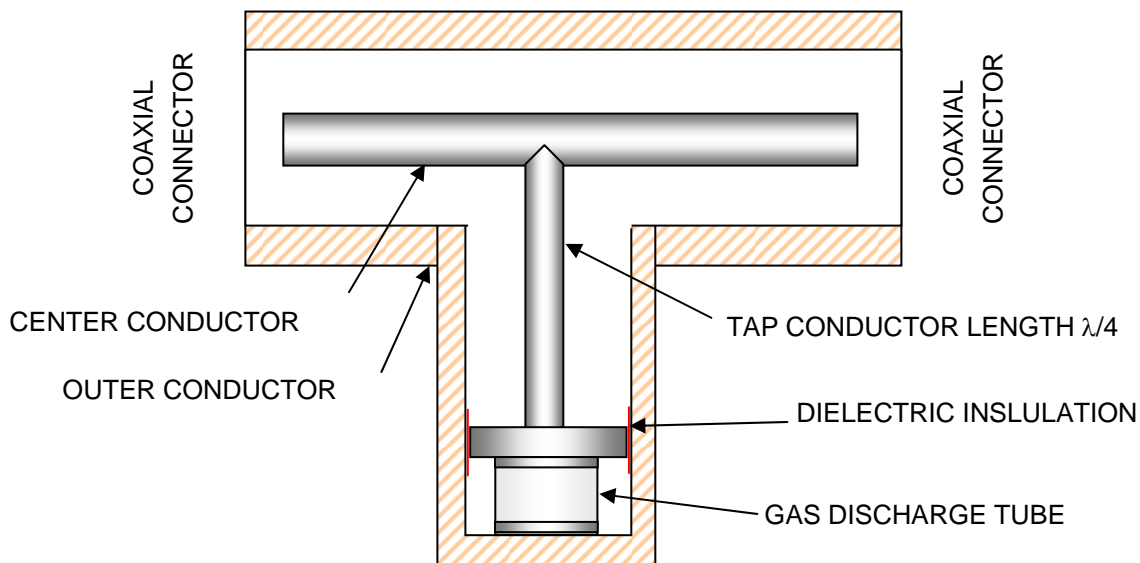

NexTek PGT SIMPLIFIED DIAGRAM